

®

PLANET

AMD 1,2 MPa (12 bar)

SPIN-ON FILTERS WITH DIFFERENTIAL INDICATORS

WECHSELPATRONEN - FILTER (Spin-on) MIT DIFFERENZANZEIGE

FILTRES SPIN-ON AVEC INDICATEURS DIFFERENTIEL

FILTRI AVVITABILI (Spin-on) CON INDICATORI DIFFERENZIALI

FILTROS SPIN-ON CON INDICADORES DIFFERENCIALES

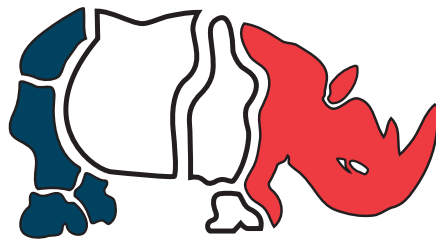

FILTERS
HYDRAULIC

COMPANY WITH
ENVIRONMENTAL MANAGEMENT
SYSTEM CERTIFIED BY DNV
= ISO 14001 =

COMPANY
WITH QUALITY SYSTEM
CERTIFIED BY DNV
= ISO 9001/2000 =

PLANET FILTERS S.p.A.
Via S.Chierico, 24
24060 BOLGARE (BG) ITALY
Tel ++39.035 (44938.21)
Fax ++39.035 (84.37.38)
E-mail: info@planetfilters.it
Http://www.sofima-hyd.com

GB Inline spin-on filters - AMD series -

DESCRIPTION: AMD series filters are especially designed for the filtration of hydraulic fluids and lubricating oils on power units, off-line systems, agricultural and construction equipment. Quick and easy element replacement.

Port sizes: 3/4" - 1 1/4" - 1 1/2" BSP - NPT and SAE 3000 flange - **Flow rates:** 7 ÷ 375 L/min

TECHNICAL DATA

Max. working pressure: 1,2 MPa (12 bar)
Max. test pressure: 1,5 MPa (15 bar)
Burst pressure: 2,5 MPa (25 bar)
Fatigue test: 0 ÷ 1,2 MPa (12 bar) / 100.000 cycles
Head: die cast aluminium
By pass valve: when fitted, is into the filter head
Working temperature: -25 ÷ +110°C

FILTER ELEMENTS

Inorganic fibres: 3µ - 6µ - 12µ - 25µ Abs.
Special paper: 10µ - 25µ
Steel wire mesh: 60µ - 125µ
Special execution on request.

FILTER ELEMENTS COLLAPSE PRESSURES

Standard: Δp 400 kPa (4 bar)

SEALS Standard: Buna-N - On request: Viton

All tests performed according to the following standards: **ISO 2941:** Element collapse resistance test - **ISO 2942:** Production integrity test **ISO 2943:** Fluids compatibility - **ISO 3723:** End load test method - **ISO 3724:** Flow fatigue resistance method - **ISO 3968:** Pressure drop versus flow rate - **ISO 16889:** Multipass test. For further information contact our Technical Dept.

D Leitungs-Anschraubfilter - AMD Serie -

KURZBESCHREIBUNG: Die Filter der Serie AMD eignen sich besonders zum Filtrieren von hydraulischen Flüssigkeiten und Schmierölen bei Antrieben jeglicher Art, offenen Kreislauf-Systemen, Land- und Baumaschinen. Die Elemente sind schnell und einfach austauschbar. **Anschlüsse:** 3/4"-1 1/4"-1 1/2" BSP-NPT und SAE 3000 Flansch - **Nennvolumenstrom:** 7 ÷ 375 L/min

TECHNISCHE DATEN

Max. Betriebsdruck: 1,2 MPa (12 bar)
Max. Prüfdruck: 1,5 MPa (15 bar)
Min. Berstdruck: 2,5 MPa (25 bar)
Dauerversuch: 0 ÷ 1,2 MPa (12 bar) / 100.000 Zyklen
Kopf: Aluminium
Bypass - Ventil: auf Wunsch
Betriebstemperatur: -25 ÷ +110°C

FILTERELEMENTE

Anorganische Fasern: 3µ - 6µ - 12µ - 25µ Abs.
Spezial Papier: 10µ - 25µ
Metallsieb: 60µ - 125 µ
Sonderausführungen auf Wunsch.

KOLLAPSDRÜCKE DES FILTERELEMENTS

Standard: Δp 400 kPa (4 bar)

DICHTUNGEN Standard: Buna-N - Auf Wunsch: Viton

Alle Proben wurden nach folgenden Normen durchgeführt: **ISO 2941:** Kollaps u. Berstdruckprüfung - **ISO 2942:** Feststellung der einwandfreien Fertigungsqualität - **ISO 2943:** Prüfung der Verträglichkeit mit der Druckflüssigkeit - **ISO 3723:** Verfahren zur Prüfung der Endscheibenbelastung **ISO 3724:** Nachweis der Durchfluss-Ermüdungseigenschaften - **ISO 3968:** Durchflusswiderstand gegen Volumenstrom - **ISO 16889:** Multipass test

F Filtres spin-on pour montage en ligne - série AMD -

DESCRIPTION: Les filtres de la série AMD sont prévus pour être utilisés sur des systèmes hydrauliques ou de lubrification. Montage sur centrales de puissance fixes ou mobiles, système off-line, agriculture, industrie.

Raccordements: 3/4" - 1 1/4" - 1 1/2" BSP - NPT et bride SAE 3000 **Débits:** 7 ÷ 375 L/min

INFORMATIONS TECHNIQUES

Pression max. de service: 1,2 MPa (12 bar)
Pression max. d'essai: 1,5 MPa (15 bar)
Pression d'éclatement: 2,5 MPa (25 bar)
Essai de fatigue: 0 ÷ 1,2 MPa (12 bar) / 100.000 cycles
Tête du filtre: fonte d'aluminium
Valve de by-pass: sur demande et montés dans la tête filtre
Temperature de travaille: -25 ÷ +110°C

ELEMENTS FILTRANTS

Fibres inorganiques: 3µ - 6µ - 12µ - 25µ Abs.
Papier special: 10µ - 25µ
Treillis metal: 60µ - 125µ
Production special sur demande.

PRESSION D'ECRASEMENT ELEMENTS FILTRANTS

Standard: Δp 400 kPa (4 bar)

JOINTS Standard: Buna-N - Sur demande: Viton

Tous les tests sont réalisés selon les standards suivant: **ISO 2941:** Test de pression d'écrasement élément filtrant - **ISO 2942:** Conformité aux détails de production - **ISO 2943:** Compatibilité media/fluids - **ISO 3723:** Détermination résistance à la déformation axiale - **ISO 3724:** Détermination résistance selon variation du débit - **ISO 3968:** Détermination des pertes de charge selon le débit - **ISO 16889:** Test Multipass.

E Filtros spin-on para montaje en linea - serie AMD -

DESCRIPCION: Los filtros de la serie AMD se emplean tanto en instalaciones oleodinámicas como de lubricación.

Aplicables en centrales de potencia fijas ó móviles, sistemas off-line, maquinaria, agrícola y de obra pública, industrias.

Conexiones: 3/4" - 1 1/4" - 1 1/2" BSP - NPT con brida SAE 3000 - **Caudal:** 7 ÷ 375 L/min

CARACTERISTICAS TÉCNICAS

Presión máx. de servicio: 1,2 MPa (12 bar)
Presión máx. de prueba: 1,5 MPa (15 bar)
Presión de rotura: 2,5 MPa (25 bar)
Ensayo de fatiga: 0 ÷ 1,2 MPa (12 bar) / 1.000.000 ciclos
Cabezal: fundición de aluminio
Válvula by-pass: bajo demanda y montada dentro del cabezal
Temperatura de servicio: -25 ÷ +110°C

ELEMENTOS FILTRANTES

Fibra inorgánica: 3µ - 6µ - 12µ - 25µ Abs.
Tela metálica: 10µ - 25µ
Ejecución especial bajo demanda.

PRESION DE APLASTAMIENTO DE LOS ELEMENTOS FILTRANTES

Estandar: Δp 400 kPa (4 bar)

JUNTAS Estandar: Buna-N - Bajo demanda: Viton

Todos los ensayos se realizan según las normas siguientes: **ISO 2941:** Verificación de la presión de aplastamiento del cartucho - **ISO 2942:** Verificación de conformidad a la fabricación - **ISO 2943:** Compatibilidad de los materiales con los fluidos - **ISO 3723:** Prueba de resistencia a la deformación axial - **ISO 3724:** Prueba de resistencia a la fatiga - **ISO 3968:** Pérdidas de carga según el caudal - **ISO 16889:** Prueba multipass

I Filtri spin-on per montaggio in linea - serie AMD -

DESCRIZIONE: I filtri della serie AMD sono utilizzabili sia in impianti oleodinamici che in impianti di lubrificazione.

Applicabili su centrali di potenza fisse o mobili, sistemi off-line, macchine agricole, movimento terra e industriali.

Attacchi: 3/4" - 1 1/4" - 1 1/2" BSP - NPT e flange SAE 3000 **Portate:** 7 ÷ 375 L/min

CARATTERISTICHE TECNICHE

Pressione max. di esercizio: 1,2 MPa (12 bar)
Pressione max. di collaudo: 1,5 MPa (15 bar)
Pressione di scoppio: 2,5 MPa (25 bar)
Test di fatica: 0 ÷ 1,2 MPa (12 bar) / 100.000 cicli
Testata: fusione di alluminio
Valvola di by-pass: se richiesta è montata nella testata filtro
Temperatura di lavoro: -25 ÷ +110°C

ELEMENTI FILTRANTI

Fibra inorganica: 3µ - 6µ - 12µ - 25µ Abs.
Carta speciale: 10µ - 25µ
Tela metallica: 60µ - 125µ
Esecuzioni speciali su richiesta.

PRESSIONE COLLASSO CARTUCCE FILTRANTI

Standard: Δp 400 kPa (4 bar)

GUARNIZIONI Standard: Buna-N - A richiesta: Viton

Tutti i test sono stati eseguiti secondo le seguenti norme: **ISO 2941:** Test verifica pressione collasso cartuccia - **ISO 2942:** Test verifica di conformità di fabbricazione - **ISO 2943:** Test verifica compatibilità materiali con fluidi - **ISO 3723:** Test per resistenza alla deformazione assiale **ISO 3724:** Test determinazione resistenza alla fatica - **ISO 3968:** Test perdite di carico in funzione della portata - **ISO 16889:** Prova Multipass

AMD 15 / 30

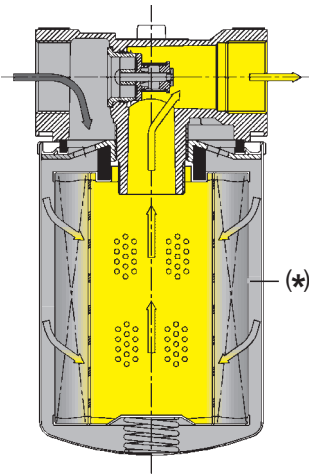

AMD 60

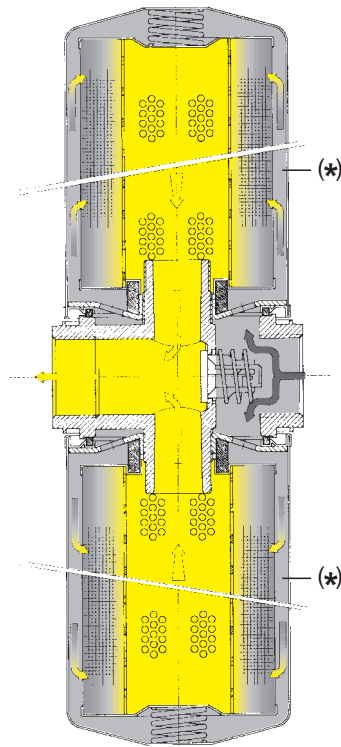

AMD 80

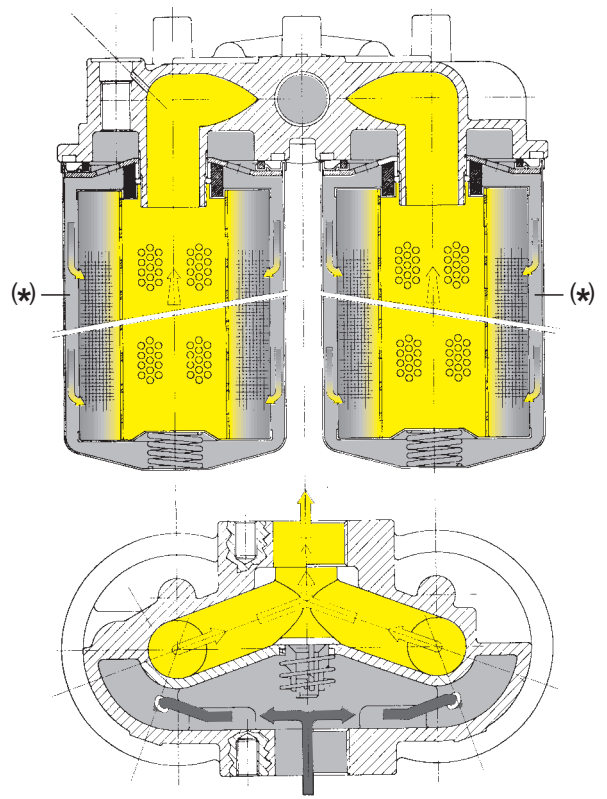

STANDARD
EUROPA

(*)

STANDARD
AMERICA

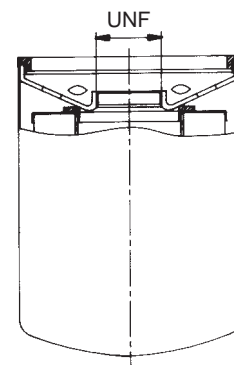
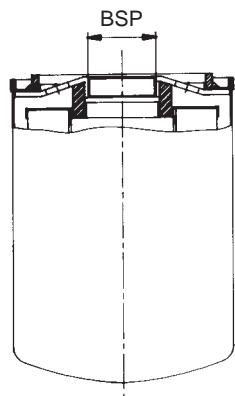

AMF□□□□□□□□B□□□X → CCA□□□E□□□
AMF□□□□□□□□F□□□X

AMF□□□□□□□□N□□□X → CCA□□□A□□□
AMF□□□□□□□□D□□□X

AMD 15

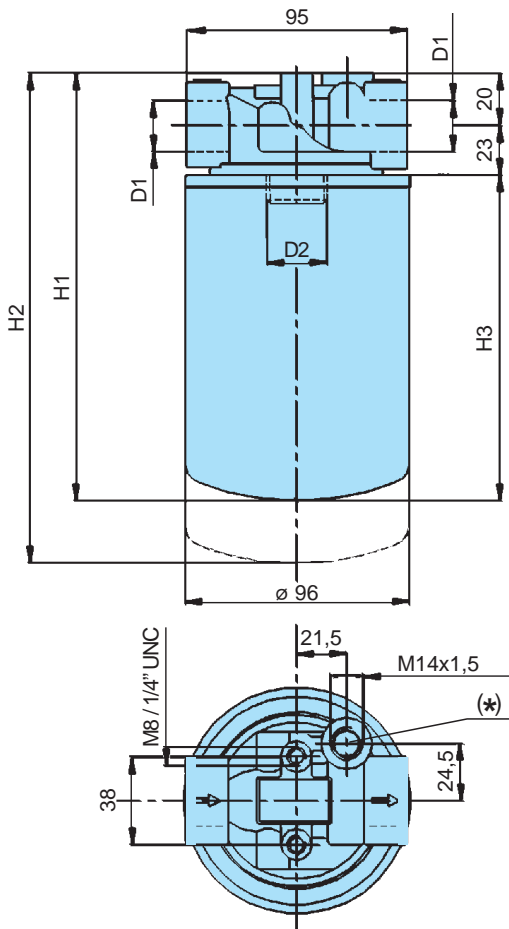

AMD 30

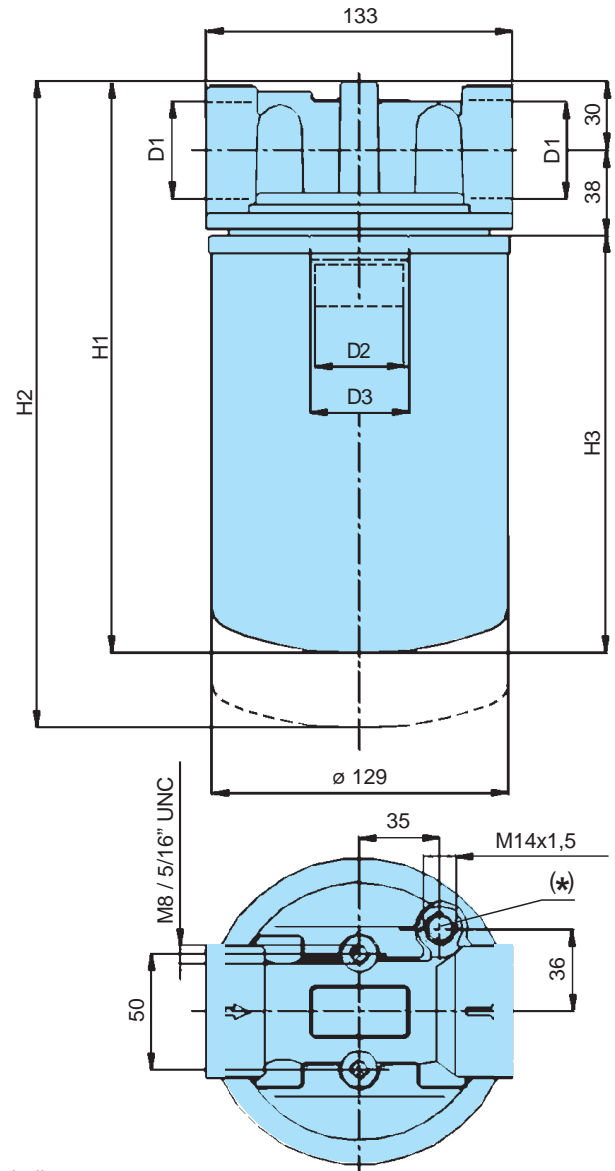

(*) Indicator port - Anschluß anzeige - Raccordement pour indicateur - Sede per indicatore

Type Typ	Type Tipo	D1	D2	D3	D4	H1	H2	H3	Kg	
AMD 151....B	3/4" BSP	3/4" BSP	-	-	M8	188	208	145	0,8	
AMD 152....B						234	254	191	0,9	
AMD 151....N	3/4"NPT	1" 12 UNF	-	-	1/4"UNC	188	208	145	0,8	
AMD 152....N						234	254	191	0,9	
AMD 301....B	1 1/4"BSP	1 1/2" 16 - UNF	1 1/4"BSP	-	M8	248	278	181	1,8	
AMD 302....B						293	323	226	1,9	
AMD 301....N	1 1/4"NPT			-	-	5/16"UNC	241	271	175	1,95
AMD 302....N							335	365	270	2,1

AMD 60

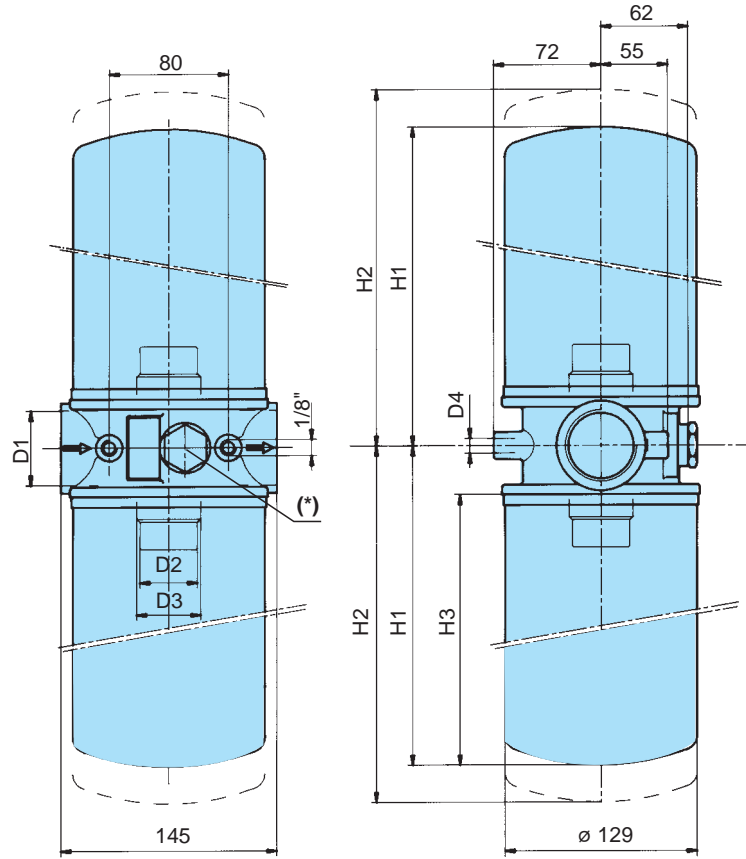

AMD 80

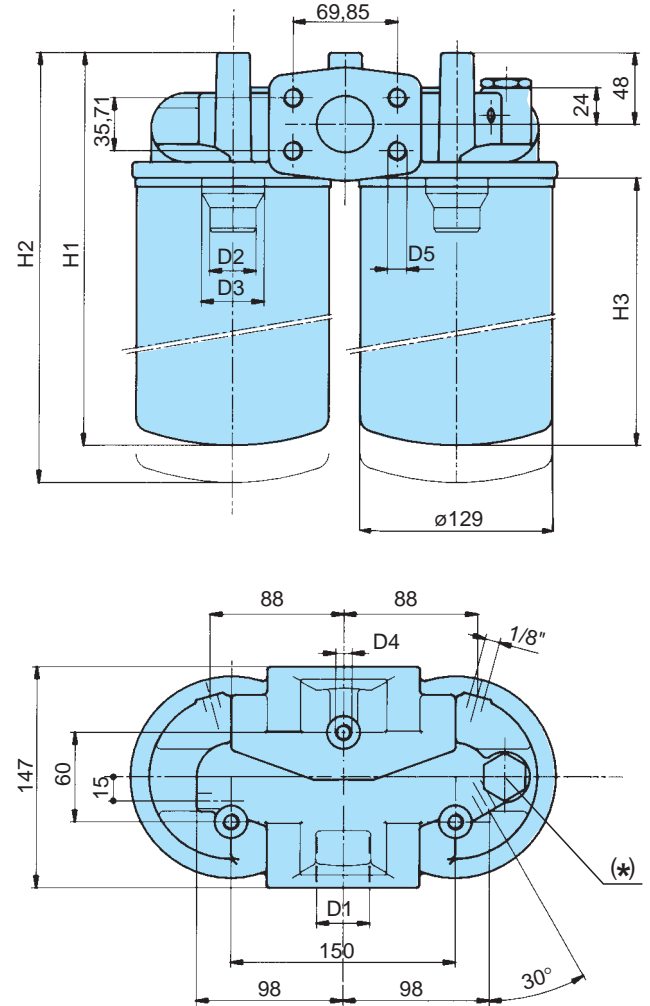

(*) Indicator port - Anschluß anzeige - Raccordement pour indicateur - Sede per indicatore

Type Typ	Type Tipo	D1	D2	D3	D4	D5	H1	H2	H3	Kg
AMD 601.... B	1 1/2" BSP	1 1/2" BSP	1 1/2" 16 - UN	1 1/4" BSP	M10	-	216	246	181	3,4
AMD 602.... B					3/8" UNC	-	209	239	175	3,5
AMD 601.... N	1 1/2" NPT	1 1/2" NPT	1 1/2" 16 - UN	1 1/4" BSP	3/8" UNC	-	305	335	270	4,2
AMD 602.... N							269	299	181	4,7
AMD 801.... B	1 1/2" BSP	1 1/2" SAE 3000	1 1/4" BSP	1 1/2" 16 - UN	M10	-	269	299	181	4,7
AMD 802.... B					-	M12	314	344	226	5,1
AMD 801.... F	1 1/2" NPT	1 1/2" NPT	1 1/4" BSP	1 1/2" 16 - UN	3/8" UNC	-	262	292	175	4,75
AMD 802.... F							357	387	270	5,4
AMD 801.... N	1 1/2" NPT	1 1/2" SAE 3000	1 1/4" BSP	1 1/2" 16 - UN	-	1/2" UNC	262	292	175	4,75
AMD 802.... N							357	387	270	5,4
AMD 801.... D	1 1/2" SAE 3000	1 1/2" SAE 3000	1 1/4" BSP	1 1/2" 16 - UN	-	1/2" UNC	262	292	175	4,75
AMD 802.... D							357	387	270	5,4

U0

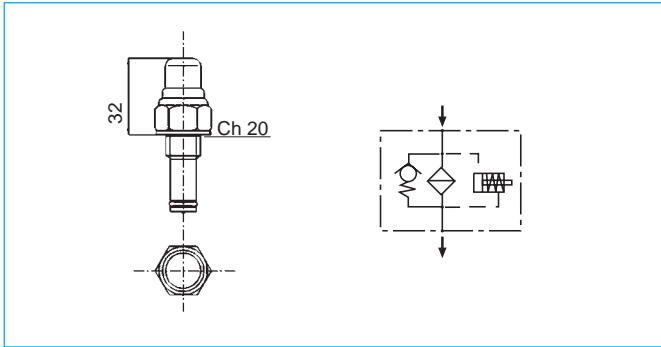

60&T0

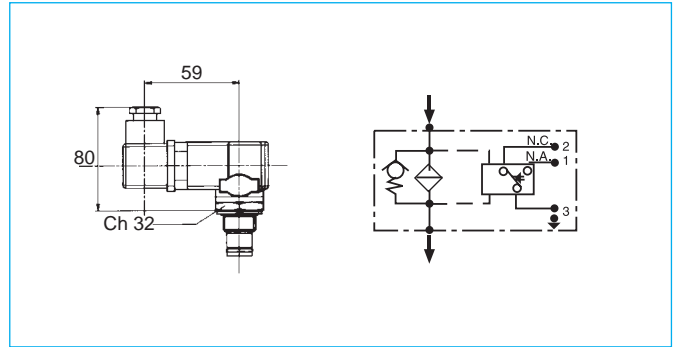

N0

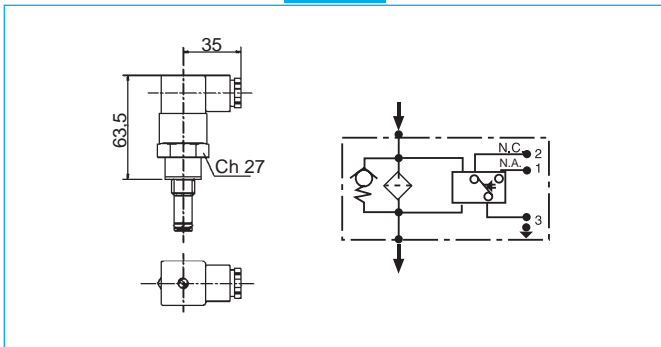

70

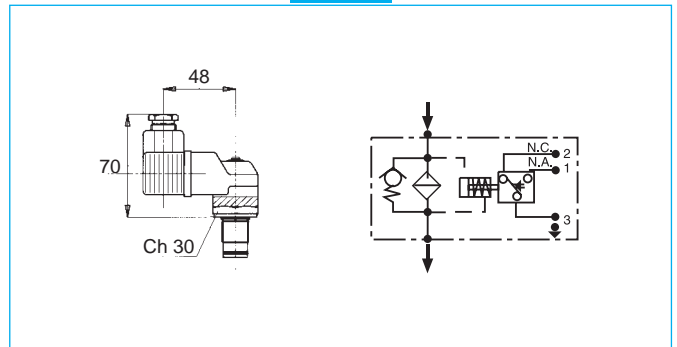

50

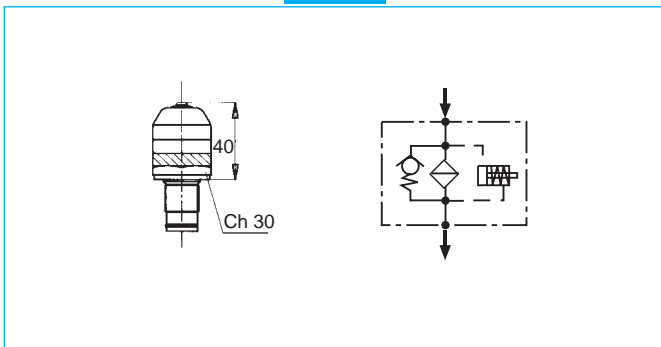

Series Série Serie Serie	Setting Einstellung Réglage Taratura	Type Typ Type Tipo
U0	1,3 bar (130 kPa)	Visual Optischer Visuel Visivo
N0	1,3 bar (130 kPa)	Electrical Elektrisch Électrique Elettrico
50	1,3 bar (130 kPa)	Visual differential Optischer Différentiel visuel Differenziale visivo

Series Série Serie Serie	Setting Einstellung Réglage Taratura	Type Typ Type Tipo
60	1,3 bar (130 kPa)	Electrical - IP65 - Connection plug DIN43650 Elektrisch - IP65 - Steck-Verbindung nach DIN43650 Électrique - IP65 - Raccordement DIN43650 Elettrico - IP65 - Connessione DIN43650
T0	1,3 bar (130 kPa)	indicator 60 with thermostat - mit Thermostat 30°C avec thermostat - con termostato
70	1,3 bar (130 kPa)	Vis.-elec. - IP65 - Connection plug DIN43650 Opt./ Elek. - IP65 - Steck-Verbindung nach DIN43650 Visuel-électrique - IP65 - Raccordement DIN43650 Visivo ed elettrico - IP65 - Connessione DIN43650

**CARTRIDGES FILTERING CAPACITY
 FILTERLEISTUNG
 CAPACITE FILTRANTE DES CARTOUCHES
 CAPACITÀ FILTRANTE CARTUCCE
 (MULTIPASS TEST ISO 4572)**

Filter elements Filtermaterialien Elementi filtranti	Δp kPa	β_x Ratio β_x Verhältnis		Rapport β_x Rapporto β_x	
		β_3	β_6	β_{12}	β_{25}
FT 3 μ	400	120	275	1045	>5000
FC 6 μ	400	38	120	330	>5000
FD 12 μ	400	7	30	165	640
FV 25 μ	400	1	2	6	138
CD 10 μ	400	1	1,5	2	5
CV 25 μ	400	1	1	1,5	2

**SPIN-ON ELEMENTS DIMENSIONAL LAYOUT
 ELEMENTE TECHNISCHE MASSDATEN
 DIMENSIONS CARTOUCHES VISSABLES
 DIMENSIONI CARTUCCE AVVITABILI**

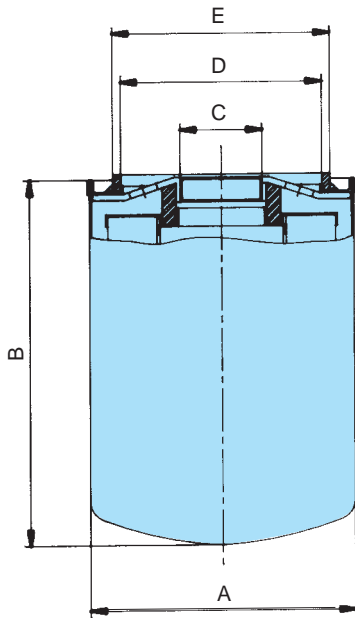

Type Typ	Type Tipo	A	B	C	D	E	Kg
CCA 151 E	95	145	62	3/4" BSP	72	0,6	
CCA 151 A				1" - 12UNF			
CCA 152 E	191	181	98	3/4" BSP	108	0,7	
CCA 152 A				1" - 12UNF			
CCA 301 E	129	226	112,5	1 1/4" BSP	112,5	1,15	
CCA 302 E						1,4	

Solo su richiesta
On request only

Nur auf Anfrage
Sur demande

CCA 155	95	90	3/4" BSP	62	72	0,4
---------	----	----	----------	----	----	-----

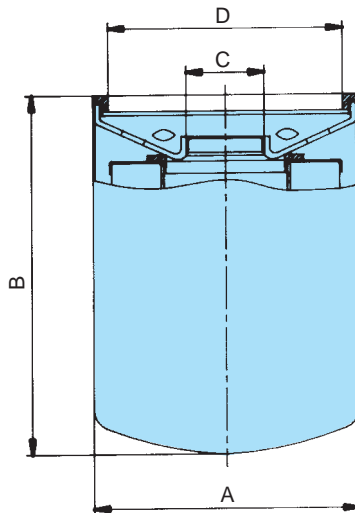

Type Typ	Type Tipo	A	B	C	D	Kg
CCA 301 A	129	270	112,5	1 1/2 - 16UNF	112,5	1,2
CCA 302 A						1,6

**FLOW RATES
NENNVOLUMENSTROM**

(L/min)

**DEBITS
PORTATE**

Type Typ	Type Tipo	FT	FC	FD	FV	CD	CV	MS	MN
AMD151		30	35	48	65	68	73	80	80
AMD152		34	41	55	69	74	80	90	90
AMD301		87	102	118	125	130	170	190	190
AMD302		92	110	125	135	150	188	205	205
AMD601		190	242	270	280	290	325	360	360
AMD602		205	255	283	292	305	340	375	375
AMD801		190	242	270	280	290	325	360	360
AMD802		205	255	283	292	305	340	375	375

The reference fluid has a kinematic viscosity of 30 cSt and a density of 0,86 Kg/dm³

Fluid de référence avec viscosité de 30 cSt et densité de 0,86 Kg/ dm³

Bezugsflüssigkeit mit kinematische Viskosität von 30 cSt und Dichte von 0,86 Kg/ dm³

Fluido di riferimento con viscosità cinematica di 30 cSt e densità di 0,86 Kg/ dm³

DIRT HOLDING CAPACITY SCHMUTZANSAMMLUNGSKAPAZITÄT CAPACITE D'ACCUMULATION CAPACITÀ D'ACCUMULO								(g)ACFTD $\Delta p = 400 \text{ kPa}$		FILTER AREA FILTERFLÄCHE SURFACE FILTRANTE SUPERFICIE FILTRANTE	
Type Typ	Type Tipo	FT	FC	FD	FV	CD	CV	MS	MN		
CCA 151E...		10,7	15,0	17,1	26,1	23,4	37,0	980	980		
CCA 151A...											
CCA 152E...		18,1	25,4	29,0	43,9	33,6	53,1	1390	1390		
CCA 152A...											
CCA 301E...		22,2	31,1	35,6	54,2	39,4	62,2	1940	1940		
CCA 301A...		19,8	27,8	31,7	48,3	35,2	55,5	1740	1740		
CCA 302E...		29,4	41,2	46,8	71,8	52,2	82,4	2570	2570		
CCA 302A...		35,2	49,3	56,3	85,8	62,5	98,5	3080	3080		