

®

PLANET
SO

CLOGGING INDICATORS

VERSCHMUTZUNGSANZEIGEN

INDICATEURS DE COLMATAGE

INDICADORES DE COLMATAJE

INDICATORI DI INTASAMENTO

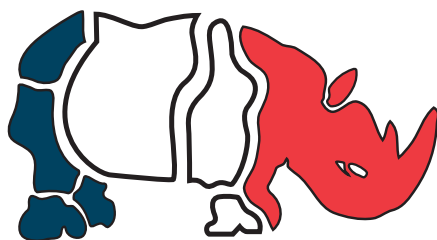

FILTERS
HYDRAULIC

COMPANY WITH
ENVIRONMENTAL MANAGEMENT
SYSTEM CERTIFIED BY DNV
= ISO 14001 =

COMPANY
WITH QUALITY SYSTEM
CERTIFIED BY DNV
= ISO 9001/2000 =

PLANET FILTERS S.p.A.
Via S.Chierico, 24
24060 BOLGARE (BG) ITALY
Tel ++39.035 (44938.21)
Fax ++39.035 (84.37.38)
E-mail: info@planetfilters.it
Http://www.sofima-hyd.com

CLOGGING INDICATORS VERSCHMUTZUNGSANZEIGEN

INDICATEURS DE COLMATAGE INDICATORI DI INTASAMENTO

VACUUM GAUGE - VAKUUMMETER - VACUOMETRE - VUOTOMETRI

Series Serie Série Serie		
10		
Series Serie Série Serie		
11		

VACUUM SWITCH - VAKUUMSCHALTER - INTERRUPTEUR A VIDE - VUOTOSTATI

Series Serie Série Serie	Description Kurzbeschreibung Description Descrizione		
21	0+0,8 bar (0+80 kPa) SPDT, adjustable SPDT, justierbar SPDT, réglable SPDT, regolabile		
Series Serie Série Serie	Description Kurzbeschreibung Description Descrizione		
S8	0,25 bar (25 kPa) Visual - Optish Visuel - Visivo		
Series Serie Série Serie	Description Kurzbeschreibung Description Descrizione		
90	0,2 bar (200 kPa) N.O. - N.O. - N.O. - N.A.		
Series Serie Série Serie	Description Kurzbeschreibung Description Descrizione		
92	0,2 bar (200 kPa) N.C. - N.C. - N.F. - N.C.		
<ul style="list-style-type: none"> - max voltage 220 Vca 50-60 Hz - max 0,5 A (Ohmsche Last) - max 0,25 A inductive - switching power 100 VA - protection IP65 - max 220 Vca 50-60 Hz - max 0,5 A résistive (Ohmsche Last) - max 0,25 A inductive - puissance de commutation 100 VA - protection IP65 - max 220 Vca 50-60 Hz - max 0,5 A resistiva - max 0,25 A induttiva - potenza commutabile 100 VA - protezione IP65 - max 220 Vca 50-60 Hz - max 0,5 A resistiva - max 0,25 A induttiva - potenza commutabile 100 VA - protezione IP65 			
Series Serie Série Serie	Description Kurzbeschreibung Description Descrizione		
L1	0,2 bar (20 kPa) SPDT SPDT contacts de rachage contatti in scambio		
Series Serie Série Serie	Description Kurzbeschreibung Description Descrizione		
91	0,2 bar (20 kPa) SPDT SPDT contacts de rachage contatti in scambio		
<ul style="list-style-type: none"> - Max voltage 250V - 50 Hz, max current 6 A resistive, 1 A inductive, protection IP65 - Max 250V - 50 Hz, max 6 A (Ohmsche Last), max 1 A (induktive Last), Schutzart IP65 - Max 250V - 50 Hz, max 6 A resistiva, max 1 A induttiva, protezione IP65 - Max 250V - 50 Hz, max 6 A resistiva, max 1 A induttiva, protezione IP65 			

PRESSURE GAUGE - MANOMETER - MANOMETRE - MANOMETRI

Series Serie Série Serie	Description Kurzbeschreibung Description Descrizione		
30	0+6 bar (0+600 kPa)		
Series Serie Série Serie	Description Kurzbeschreibung Description Descrizione		
32	0+6 bar (0+600 kPa)		
Series Serie Série Serie	Description Kurzbeschreibung Description Descrizione		
31	0+12 bar (0+1,2 MPa)		
Series Serie Série Serie	Description Kurzbeschreibung Description Descrizione		
33	0+12 bar (0+1,2 MPa)		

PRESSURE SWITCH - DRUCKSCHALTER - PRESSOSTAT - PRESSOSTATI

Series Serie Série Serie	Description Kurzbeschreibung Description Descrizione		
R8	1,5 bar (150 kPa) Visual Optisher Visuelle Visivo		
Series Serie Série Serie	Description Kurzbeschreibung Description Descrizione		
P1	SPDT SPDT contacts de rachage contatti in scambio 1,5 bar (150 kPa)		
Series Serie Série Serie	Description Kurzbeschreibung Description Descrizione		
P6	2 bar (200 kPa)		
Series Serie Série Serie	Description Kurzbeschreibung Description Descrizione		
80	1,5 bar (150 kPa) N.O. - N.O. - N.O. - N.A.		
Series Serie Série Serie	Description Kurzbeschreibung Description Descrizione		
81	1,5 bar (150 kPa) N.C. - N.C. - N.F. - N.C.		
Series Serie Série Serie	Description Kurzbeschreibung Description Descrizione		
84	1,3 bar (130 kPa) N.O. - N.O. - N.O. - N.A.		
Series Serie Série Serie	Description Kurzbeschreibung Description Descrizione		
85	1,3 bar (130 kPa) N.C. - N.C. - N.F. - N.C.		
Series Serie Série Serie	Description Kurzbeschreibung Description Descrizione		
86	2 bar (200 kPa) N.O. - N.O. - N.O. - N.A.		
Series Serie Série Serie	Description Kurzbeschreibung Description Descrizione		
87	2 bar (200 kPa) N.C. - N.C. - N.F. - N.C.		
<ul style="list-style-type: none"> Max voltage 220 Vca 50-60 Hz - max current 0,5 A resistive, 0,25 A inductive - switching power 100 VA - protection IP65 Max 220 Vca 50-60 Hz - max 0,5 A (Ohmsche Last), max 0,25 A (induktive Last) - Schaltleistung 100 VA - Schutzart IP65 Max 220 Vca 50-60 Hz - max 0,5 A resistiva, max 0,25 A induttiva - potenza commutabile 100 VA - protezione IP65 Max 220 Vca 50-60 Hz - max 0,5 A resistiva, max 0,25 A induttiva - potenza commutabile 100 VA - protezione IP65 			

DIFFERENTIAL - DIFFERENZANZEIGE - DIFFERENTIEL - DIFFERENZIALI

> VISUAL - OPTISCHER - VISUELLE - VISIVI

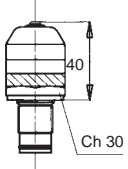
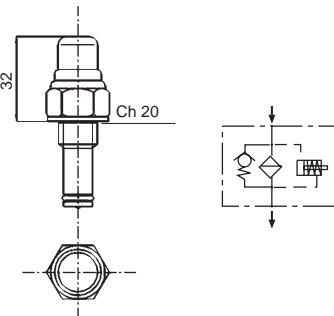
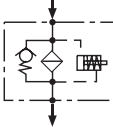
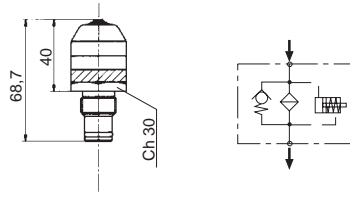
Series Serie Série Serie	Description Kurzbeschreibung Description Descrizione		Series Serie Série Serie	Description Kurzbeschreibung Description Descrizione		
50	1,3 bar (130 kPa)		U0	1,3 bar (130 kPa)		
51	2 bar (200 kPa)					
52	5 bar (500 kPa)					
53	8 bar (500 kPa)					
56	2,5 bar (250 kPa)					
K2	5 bar (500 kPa)		K3	8 bar (800 kPa)		

> ELECTRICAL - ELEKTRISCH - ELECTRIQUE - ELETTRICI

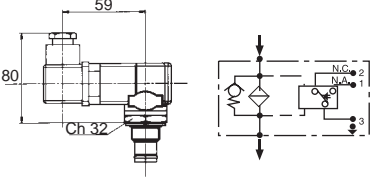
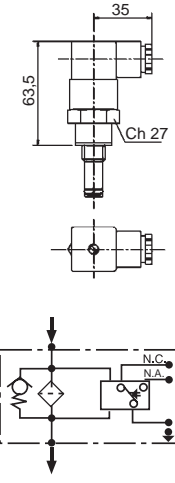
Series Serie Série Serie	Description Kurzbeschreibung Description Descrizione		Series Serie Série Serie	Description Kurzbeschreibung Description Descrizione	
60	1,3 bar (130 kPa)		N0	1,3 bar (130 kPa)	
61	2 bar (200 kPa)				
62	5 bar (500 kPa)				
63	8 bar (800 kPa)				
66	2,5 bar (250 kPa)				
T0	1,3 bar (130 kPa)	indicator 60 indicator 61 indicator 62 indicator 63 indicator 66 with thermostat mit Thermostat avec thermostat con termostato 30°C			
T1	2 bar (200 kPa)				
T2	5 bar (500 kPa)				
T3	8 bar (800 kPa)				
T6	2,5 bar (250 kPa)				

> VISUAL ELECTRICAL - OPTISCH UND ELEKTRISCH - VISUELLE ELECTRIQUE - VISIVI ELETTRICI

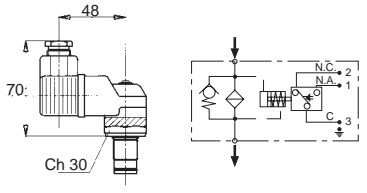
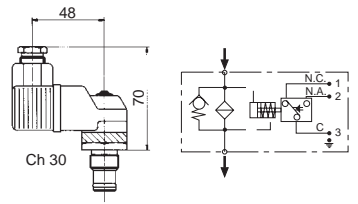
Series Serie Série Serie	Description Kurzbeschreibung Description Descrizione		Series Serie Série Serie	Description Kurzbeschreibung Description Descrizione	
70	1,3 bar (130 kPa)		Y2	5 bar (500 kPa)	
71	2 bar (200 kPa)				
72	5 bar (500 kPa)				
73	8 bar (500 kPa)				
76	2,5 bar (250 kPa)				
Y3	8 bar (800 kPa)				

For indicators 6+ - 7+ - T+

SPDT differential switch
C.A. 125-250 V:
> max resistive or inductive load 1 A

C.C. 30-50-75-125 V:
> max resistive load
2-0,5-0,25-0,2 A respectively
> max inductive load
2-0,5-0,25-0,03 A respectively

Protection IP65
Connector DIN 43650

Für Anzeige 6+ - 7+ - T+

SPDT Differenzdruckanzeige
Wechselstrom 125-250 V:
> max. Ohmsche Last/ind. Last 1A

Gleichstrom 30-50-75-125 V:
> max. Ohmsche Last
2-0,5-0,25-0,2 A resp.
> max. induktive Last
2-0,5-0,25-0,03 A resp.

Schutzart IP65
Würfelstecker nach DIN 43650

Pour indicateurs 6+ - 7+ - T+

Contacts de recharge
C.A. 125-250 V:
> charge résistive ou inductive maxi.1A

C.C. 30-50-75-125 V:
> max charge résistive
2-0,5-0,25-0,2 A resp.
> max charge inductive
2-0,5-0,25-0,03 A resp.

Protection IP65
Connecteur DIN 43650

Per indicatori 6+ - 7+ - T+

Contatti in scambio
C.A. 125-250 V:
> max carico resistivo o induttivo 1 A

C.C. 30-50-75-125 V:
> max carico resistivo
2-0,5-0,25-0,2 A rispettivamente
> max carico induttivo
2-0,5-0,25-0,03 A rispettivamente

Protezione IP65
Connettore DIN 43650